

# WELD PAD THERMOCOUPLES

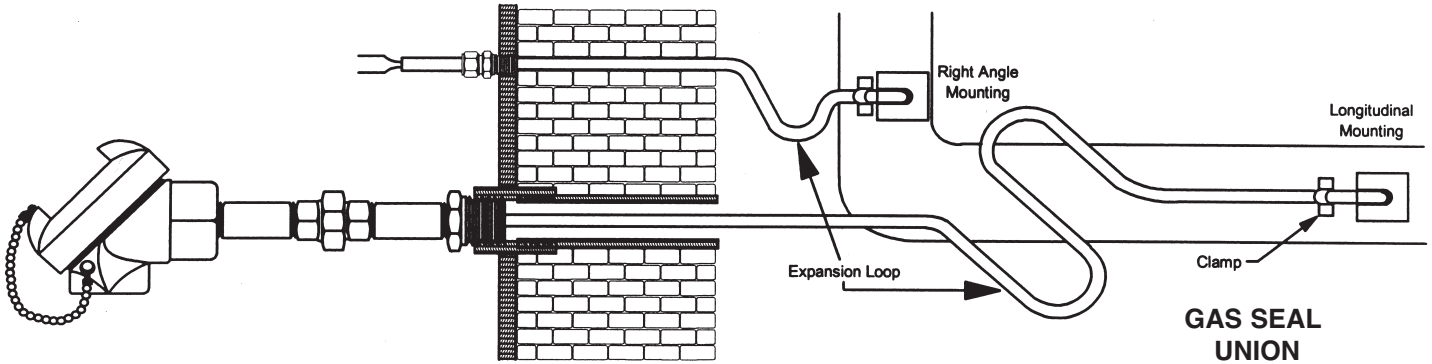

## GAS SEAL UNION

### OTHER TERMINATIONS AVAILABLE:

Spring Loaded Process Cover

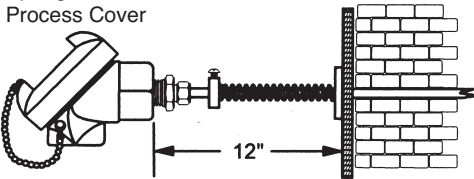

Flex Armour Leads

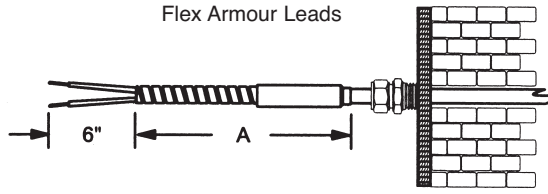

Inline Transition

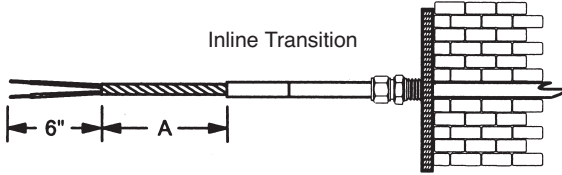

## WELD PAD CLAMP

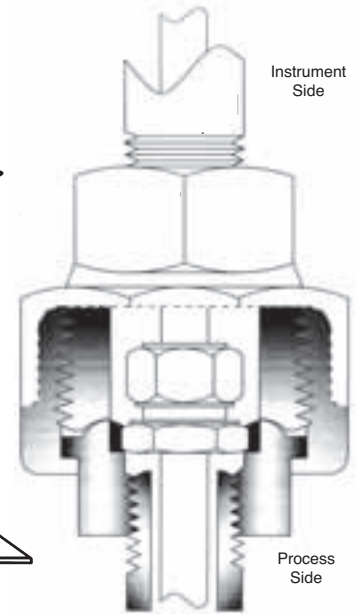
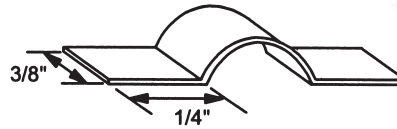

### FEATURES:

**WELD PAD:** 1" x 1" x 1/8" of same material as sheath.

**WELD PAD CLAMP:** One supplied of same material as sheath.

### TO ORDER:

WPT - X - X - X - X - X - X - X - X - X - X

BTB (A) Inches (X) Not Applicable ISA Calibration (L) Inches Pipe Diameter (Inches)

Code	Connection Head
	Specify from Page TC-9
(X)	Not Required

Code	Process Fitting
38	3/8" NPT
12	1/2" NPT
34	3/4" NPT
10	1" NPT
14	1 1/4" NPT
21	1 1/2" NPT

Code	Sheath Material
304	304 SS
310	310 SS
316	316 SS
600	Inconel 600
( )	Specify

R	Right Angle
L	Longitudinal
X	BTB (Not Applicable)

Code	Sensor Style
CF	Compression Fitting
GS	Gas Seal Union
FX	Flex Armour over Fiberglass
TX	Flex Armour over Teflon
FL	Fiberglass Lead Wire
TL	Teflon Lead Wire

Code	Probe Diameter
36	3/16"
14	1/4"
38	3/8"

## BOILER TUBE BLOCK

Patent Pending

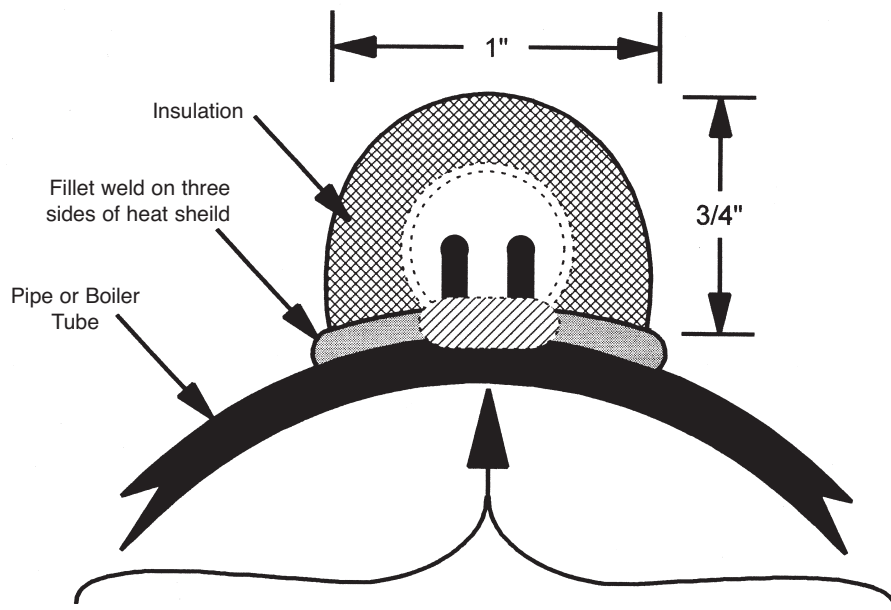

This is where the **Boiler-Tube-Block** sets itself apart from all others. A simple 1/8" fillet weld puts the junction right in the wall. The insulated heat shield over the **BTB** ensures no adverse affects from external temperature sources.

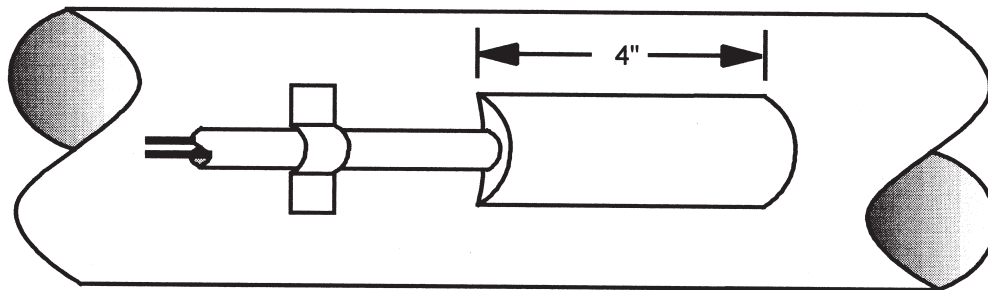

### HOW TO ORDER:

See page TC-13 for BTB

### STANDARD FEATURES :

The Boiler Tube Block (BTB) is pre-shaped to fit onto the pipe diameter specified.

Installation instructions are supplied with each set of thermocouples.

Each BTB is supplied with a weld clamp for extra support.

Unless otherwise specified, the **BTB**, **Heat Shield** and **Clamp** are the same alloy as the sheath.

A heat shield is supplied to insulate the sensor from adverse effects of external temperatures.

All instrument terminations available on the Weld Pad are also available on the BTB.